

NOTE:
Please read all instructions
carefully before using this
product

Safety Notice

Hardware Identifier

Assembly Instruction

Parts List

Warranty

Ordering Parts

Model
IVK 400

Retain This
Manual for
Reference

08-03-04

OWNER'S
MANUAL



Dumbbell Rack IVK 400

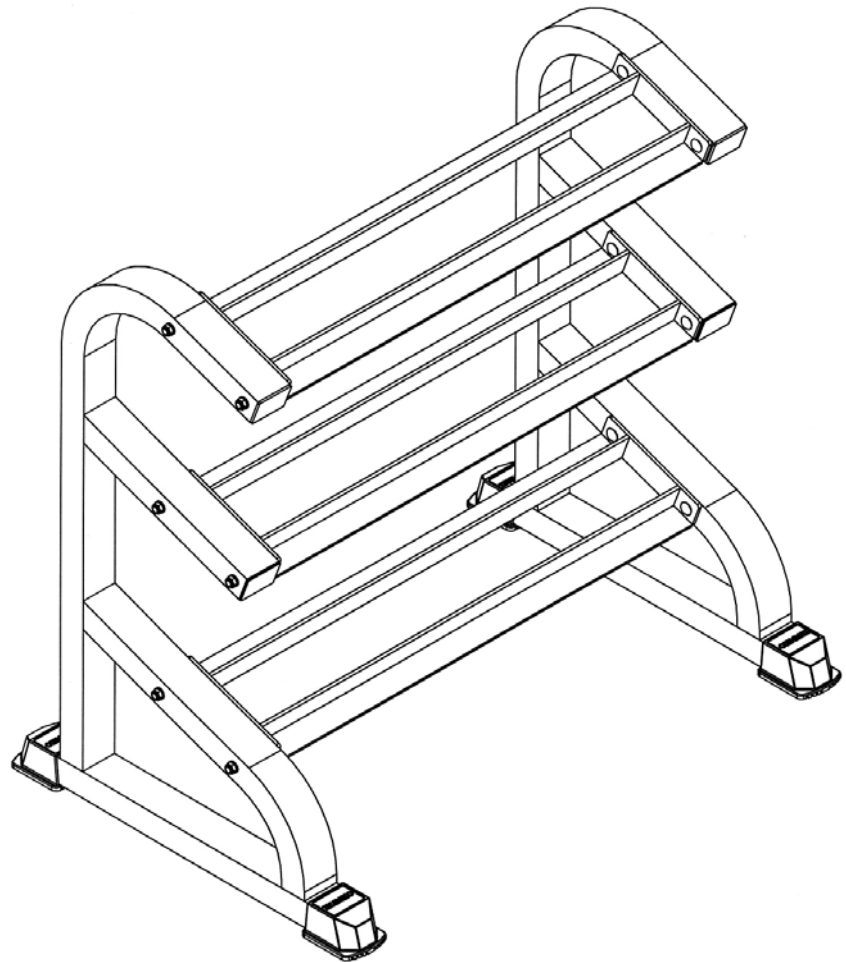

IMPEX FITNESS PRODUCTS

14777 DON JULIAN RD., CITY OF INDUSTRY, CA 91746

Tel: (800) 999-8899 Fax: (626) 961-9966

www.impex-fitness.com

info@impex-fitness.com

TABLE OF CONTENTS

BEFORE YOU BEGIN.....	1
IMPORTANT SAFETY NOTICES.....	2
HARDWARE IDENTIFIER.....	3
ASSEMBLY INSTRUCTIONS.....	4
EXPLODED DIAGRAM.....	4
PARTS LIST.....	5
WARRANTY.....	6
ORDERING PARTS.....	6

BEFORE YOU BEGIN

Thank you for selecting the IVANKO Dumbbell Rack IVK400 by IMPEX FITNESS PRODUCTS. For your safety and benefit, read this manual carefully before using the machine. As a manufacturer, we are committed to provide you complete customer satisfaction. If you have any questions, or find there are missing or damaged parts, we guarantee you complete satisfaction through direct assistance from our factory. **DO NOT RETURN THE UNIT TO THE STORE!** To avoid unnecessary delays, please call our *TOLL-FREE customer service number*. Our Customer Service Agents will provide immediate assistance to you.

<p>Toll-Free Customer Service Number 1-800-999-8899 Mon. – Fri. 9 a.m. – 5 p.m. PST www.impex-fitness.com info@impex-fitness.com</p>

IMPORTANT SAFETY NOTICE

PRECAUTIONS

This exercise equipment is built for optimum safety. However, certain precautions apply whenever you operate a piece of exercise equipment. Be sure to read the entire manual before you assemble or operate your equipment. In particular, note the following safety precautions:

1. **Keep children and pets away from the equipment at all times. DO NOT leave children unattended in the same room with the equipment.**
2. If the user experiences dizziness, nausea, chest pain, or any other abnormal symptoms, STOP the workout at once. CONSULT A PHYSICIAN IMMEDIATELY.
3. Position the equipment on a clear, leveled surface. DO NOT use the equipment near water or outdoors.
4. Always wear appropriate workout clothing when exercising. DO NOT wear robes or other clothing that could become caught in the equipment. Running or aerobic shoes are also required when exercising.
5. Use the equipment only for its intended use as described in this manual. DO NOT use attachments not recommended by the manufacturer.
6. Do not place any sharp object around the equipment.
7. Disabled person should not use the equipment without a qualified person or physician in attendance.
8. Before using the equipment to exercise, always do stretching exercises to properly warm up.
9. Never operate the equipment if the equipment is not functioning properly.

WARNING: BEFORE BEGINNING ANY EXERCISE PROGRAM, CONSULT YOUR PHYSICIAN. THIS IS ESPECIALLY IMPORTANT FOR INDIVIDUALS OVER THE AGE OF 35 OR PERSONS WITH PRE-EXISTING HEALTH PROBLEMS. READ ALL INSTRUCTIONS BEFORE USING ANY FITNESS EQUIPMENT. IMPEX INC. ASSUMES NO RESPONSIBILITY FOR PERSONAL INJURY OR PROPERTY DAMAGE SUSTAINED BY OR THROUGH THE USE OF THIS PRODUCT.

SAVE THESE INSTRUCTIONS.

HARDWARE IDENTIFIER

PLACE WASHER, END OF BOLT, OR SCREW ON CIRCLE TO CHECK FOR CORRECT SIZE.

MILLIMETERS

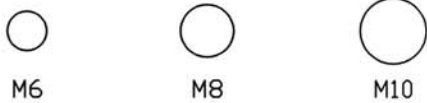

INCHES

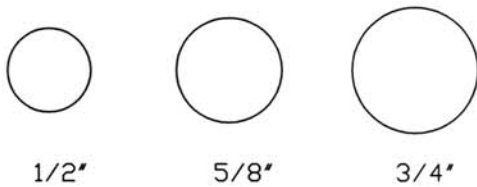

REPLACEMENT PARTS

Thank you for purchasing IMPEX Product. Although we go to great effort to ensure the quality of our products, occasionally errors or omissions occur. Should you find either a defective or missing part in this product, please contact us for a replacement at the telephone number.

QUESTION ?



1-800-999-8899

NOTE: When installing a Aircraft Nut (also called Nylon or Lock Nut), Please use two adjustable wrenches to tighten down the Nut. Hold down the Bolt with one wrench, and use the other wrench to turn the Nut clockwise.

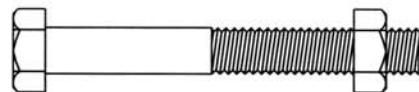
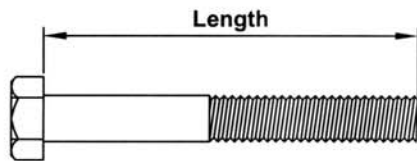

HEX HEAD BOLT

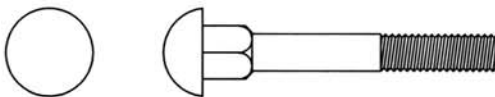

CARRIAGE BOLT



ALLEN BOLT



AIRCRAFT NUT



FLAT WASHER

ASSEMBLY INSTRUCTION

Tools Required Assembling the Machine: Adjustable Wrench

NOTE: It is strongly recommended this machine be assembled by two or more people to avoid possible injury.

STEP 1 (See Exploded Diagram)

- A.) Place a Dumbbell Rack (#2) in between the two Upright Beams (#1). Secure each end with two M10 x 3 1/2" Carriage Bolts (#6), Ø 3/4" Washers (#5), and M10 Aircraft Nuts (#7). Do not tighten the Nuts and Bolts yet.
- B.) Repeat the Procedure A to connect the other two Dumbbell Racks (#2) to the Upright Beams.
- C.) Securely tighten all Nuts and Bolts.

Exploded Diagram

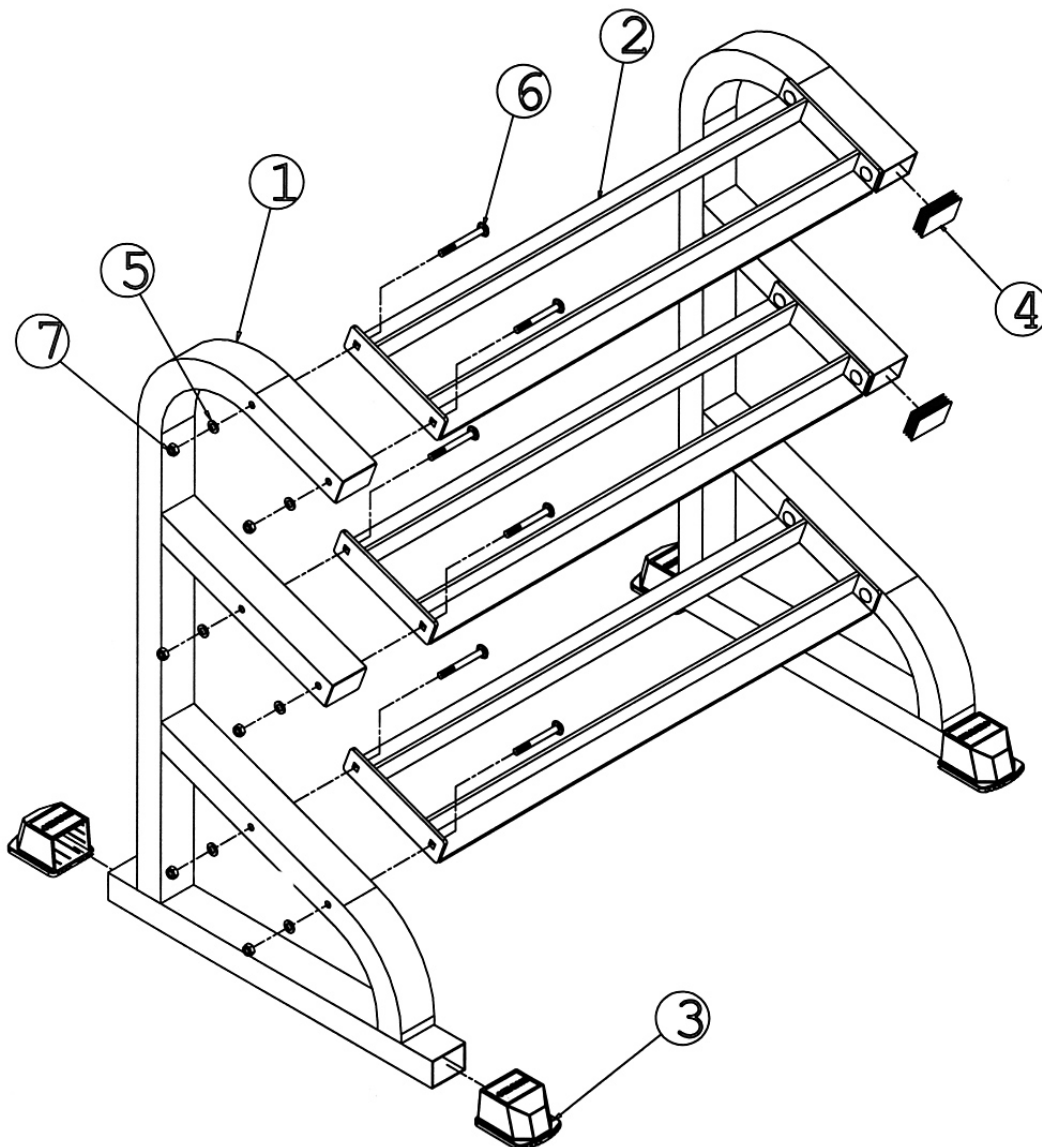

Parts list

KEY NO.	DESCRIPTION	Q'ty
1	Upright Beam	2
2	Dumbbell Rack	3
3	Upright Beam Base End Cap	4
4	2" x 2 3/4" End Cap	4
5	Ø 3/4" Washer	12
6	M10 x 3 1/2" Carriage Bolt	12
7	M10 Aircraft Nut	12

IVANKO

By IMPEX FITNESS PRODUCTS

LIMITED WARRANTY

IMPEX FITNESS PRODUCTS ("IMPEX") warrants this product to be free from defects in workmanship and material, under normal use and service conditions, for a period of 3 YEARS from the date of purchase. This warranty extends only to the original purchaser. IMPEX's obligation under this Warranty is limited to replacing or repairing, at IMPEX's option.

All returns must be pre-authorized by IMPEX. Pre-authorization may be obtained by calling IMPEX Customer Service Department at 1-800-999-8899. All freights on products returned to IMPEX must be prepaid by the customer. This warranty does not extend to any product or damage to a product caused by or attributable to freight damage, abuse, misuse, improper or abnormal usage or repairs not provided by an IMPEX authorized service center or for products used for heavy commercial or rental purposes. No other warranty beyond that specifically set forth above is authorized by IMPEX.

IMPEX is not responsible or liable for indirect, special or consequential damages arising out of or in connection with the use or performance of the product or other damages with respect to any economic loss, loss of property, loss of revenues or profits, loss of enjoyments or use, costs of removal, installation or other consequential damages or whatsoever natures. Some states do not allow the exclusion or limitation of incidental or consequential damages. Accordingly, the above limitation may not apply to you.

The warranty extended hereunder is in lieu of any and all other warranties and any implied warranties of merchantability or fitness for a particular purpose is limited in its scope and duration to the terms set forth herein. Some states do not allow limitations on how long an implied warranty lasts. Accordingly, the above limitation may not apply to you.

This warranty gives you specific legal right. You may also have other rights which vary from state to state. **Register on-line at www.impex-fitness.com**

IMPEX INC.
14777 Don Julian Rd.,
City of Industry, CA 91746

ORDERING REPLACEMENT PARTS

Replacement parts can be ordered by calling our Customer Service Department toll-free at **1-800-999-8899** during our regular business hours: Monday through Friday, 9 am until 5 pm Pacific standard time.

info@impex-fitness.com

When ordering replacement parts, always give the following information.

1. Model
2. Description of Part
3. Part Number
4. Date of Purchase